



Model Question Paper (R-20)

**K.S.R.M COLLEGE OF ENGINEERING (AUTONOMOUS), KADAPA-516003**

I-B.Tech, II-Semester

**SUB: APPLIED PHYSICS (20AP202)**

Time: 3 Hours

**(Computer Science and Engineering)**

Max.Marks:60

**Note:** Answer any **FIVE** of the following, Each Question carries **equal** marks.

**UNIT - I**

1. a. Explain the interference of light due to thin films by reflection? 06M  
b. Describe the formation of Newton's rings with necessary theory? 06M

( or )

2. a. Distinguish between Fresnel's & Fraunhofer diffraction? 04M  
b. Describe Fraunhofer diffraction due to double slit. 08M

**UNIT - II**

- 3.a. Derive the relation between various Einstein's coefficients 06M  
b. Explain the principle, construction and working of Semiconductor diode laser with a neat diagram. 06M

(or)

4. a.Explain the various types of optical fibers. 06M  
b.Derive an expression for numerical aperture of an optical fiber. 06M

**UNIT - III**

- 5.a. Explain the types of polarizations. 06M  
b. Derive the Lorentz internal field equation. 06M

(or)

6. a. Describe the origin of magnetic moment of an electron? 06M  
b. Analyze the Hysteresis curve. Write about soft and hard magnetic materials. 06M

**UNIT - IV**

7. a.Derive Schrodinger's 1-dimentional time independent wave equation. 06M  
b.Describe the behavior of a particle in a one-dimensional infinite potential well. 06M

(or)

8. a.Describe the electrical conductivity in metals using quantum free electron theory? 06M  
b.Derive the density of states and Fermi energy level. 06M

**UNIT - V**

9. a.Derive the expressions for intrinsic carrier concentration of semiconductors and Fermi energy level. 06M

- c. Define Hall Effect. Derive the Hall coefficient and its applications. 06M

(or)

10. a. Distinguish between type-I and type-II superconductors. 04M  
b. Describe the BCS Theory of superconductivity and its applications . 08M

**Subject Code: 20EC202/R20**

**K.S.R.M COLLEGE OF ENGINEERING, KADAPA  
(AUTONOMOUS)  
MODEL QUESTION PAPER  
FOUR YEAR B. TECH DEGREE EXAMINATIONS  
I B.TECH II SEMESTER REGULAR EXAMINATION  
SUB: ENGINEERING CHEMISTRY  
(CE)**

**Time : 3hrs**

**Max marks :60**

**Answer any Five questions choosing one question from each unit.**

**UNIT-I**

1. (a) Write notes on any two boiler troubles. 8 M  
(b) Discuss the specification for drinking water by BIS method. 4 M
- Or
2. (a) Describe the estimation of hardness of water by EDTA method. 6M  
(b) Explain the softened of water by ion exchange process with neat diagram. 6M

**UNIT-II**

3. (a) Define Corrosion and explain the Electrochemical theory of corrosion 8M  
(b) Discuss the lithium ion batteries. 4M
- Or
4. (a) Explain factors affecting the corrosion. 4M  
(b) Define cell potential and derive Nernst equation. 8M

**UNIT-III**

5. (a) Evaluate the process of Refining of Petroleum with neat diagram. 8M  
(b) Differences between Thermo plastics and Thermo setting plastics. 4M
- Or
6. (a) Explain the mechanism of Cationic polymerization with an example. 6M  
(b) Explain the ultimate analysis of coal. 6M

**UNIT-IV**

7. (a) Explain the mechanism of lubrication. 6M  
(b) Explain any 4 properties of lubricants. 6M

Or

8. (a) Explain any four important properties of Refractories. 4M  
(b) Write notes on Setting and Hardening of Cement 8M

**UNIT-V**

9. (a) Explain the synthesis of colloids by Electro dispersion method. 6M  
(b) Write note on Stabilization of Nano materials by stabilizing agents. 6M

Or

10. (a) Write notes on application of colloids and nanomaterials in medicine . 6M  
(b) Explain the synthesis of nanomaterials by Chemical method. 6M



# K.S.R.M. COLLEGE OF ENGINEERING

(AUTONOMOUS)

Kadapa, Andhra Pradesh, India– 516 003

I B.Tech. II Semester (R20 UG) Model paper-2021

Engineering Physics (Subject Code 20EP202)

## Mechanical Engineering

Max. Marks: 60

Answer ALL the questions. All Questions carry Equal Marks

Time: 3 Hours

5x12=60 Marks

| Q. No    | Question (s)  | Marks  |
|----------|---|--------|
| UNIT I   |   |        |
| 1        | (a) Describe interference in thin films due to reflected light.<br>(b) How colours will exhibit in thin films? Discuss .  | 8<br>4 |
| (OR)     |   |        |
| 2        | (a) What is diffraction grating? Discuss the diffraction phenomena in the plane diffraction grating and determine the grating equation.<br>(b) A parallel beam of sodium light is allowed to be incident normally on a plane having 4250 lines per cm and a second order spectral line is observed to be deviated through $30^\circ$ calculate the wavelength of light. | 8<br>4 |
| UNIT II  |   |        |
| 3        | (a) Write the difference between spontaneous and stimulated emission.<br>(b) What is Laser action? Briefly explain the solid state [Nd-YAG] laser.  | 4<br>8 |
| (OR)     |   |        |
| 4        | (a) Discuss the different types of optical fibers.<br>(b) Discuss about the propagation losses in optical fiber and analyze the applications of optical fiber.  | 6<br>6 |
| UNIT III |   |        |
| 5        | (a) Classify the magnetic materials on the basis of magnetic moment.<br>(b) Analyze the hysteresis curve. Write about soft and hard magnetic materials.   | 6<br>6 |
| (OR)     |   |        |
| 6        | (a) Describe the synthesis of nanomaterials by chemical vapour deposition.<br>(b) Write the different applications of the nanomaterials.  | 8<br>4 |
| UNIT IV  |   |        |
| 7        | (a) Define absorption coefficient and determine its value.<br>(b) Write an account on factors affecting the acoustics of buildings and their remedies.  | 4<br>8 |
| (OR)     |   |        |
| 8        | (a) Write the properties of the ultrasonics.<br>(b) Explain the production of ultrasonics by Magnetostriction method.   | 4<br>8 |

UNIT V

- 9 (a) Explain the about the crystal systems 8  
(b) Describe the procedure to find the Miller indices and mention its significance. 4

(OR)

- 10 (a) State and explain Bragg's law of X-ray diffraction. 4  
(b) Describe powder method for determination of crystal structure 8

**Faculty In-charge**

Subject Code: 2001204

| Course Title  | Strength of Materials |            |   |    | B. Tech. II Sem           |                                |           |       |
|---|-----------------------|------------|---|----|---------------------------|--------------------------------|-----------|-------|
| Course Code   | Category              | Hours/Week |   |    | Credits                   | Maximum Marks                  |           |       |
| 2001204   | ESC                   | L          | T | P  | C                         | Continuous Internal Assessment | End Exams | Total |
|   |                       | 3          | 0 | -- | 3                         | 30                             | 70        | 100   |
| Mid Exam Duration: 2Hours   |                       |            |   |    | End Exam Duration: 3Hours |                                |           |       |
| <b>Course Objectives:</b> <ul style="list-style-type: none"><li>• To make the student understand how to resolve forces and moments in a given System</li><li>• To demonstrate the student to determine the centroid and second moment of area</li><li>• To impart procedure for drawing shear force and bending moment diagrams for beams.</li><li>• To make the student able to analyze flexural stresses in beams due to different loads.</li><li>• To enable the student to apply the concepts of strength of materials in engineering applications and design problems.</li></ul> |                       |            |   |    |                           |                                |           |       |

### UNIT-I

**Introduction to Mechanics:** Basic Concepts, system of Forces -Coplanar Concurrent Forces - Components in Space Resultant -Moment of Forces and its Application - Couples and Resultant of Force Systems. Equilibrium of system of Forces: Free body diagrams, Equations of Equilibrium of Coplanar Systems and Spatial systems- **Center of Gravity and moment of inertia:** Introduction – Centroids of rectangular, circular, I, L and T sections - Centroids of built up sections. **Moment of Inertia:** Introduction – Definition of Moment of Inertia of rectangular, circular, I, L and T sections - Radius of gyration. Moments of Inertia of Composite sections.

#### Unit Outcomes:

- Understand the basic concepts of forces
- Draw Free Body Diagrams for forces
- Determine the centroid and moment of inertia for different cross section areas

### UNIT – II

#### Simple Stresses and Strains:

Types of stresses and strains – Hooke's law – Stress – strain diagram for mild steel – working stress – Factor of safety – lateral strain, Poisson's ratio and volumetric strain – Elastic moduli and the relationship between them – Bars of Varying section – Composite bars – Temperature stresses. Strain energy – Resilience – Gradual, Sudden, impact and shock loadings – simple applications.

#### Unit Outcomes

- Understand concepts of stresses, strains, elastic moduli and strain energy.
- Evaluate relations between different moduli
- Understand different type's loadings

### UNIT – III

#### Shear Force and Bending Moment:

Definition of beam – types of beams – Concept of Shear force and bending moment – S.F and B.M diagrams for cantilever, simply supported and over hanging beams subjected to point loads, uniformly distributed load, uniformly varying loads and combination of these loads – point of contra flexure – Relation between S.F, B.M and rate of loading at a section of a beam.

#### Unit Outcomes

## Subject Code: 2001204

- Draw the shear force and bending moment diagrams for cantilevers, simply supported beams and Overhanging beams with different loads
- Understand the relationship between shear force and bending moments

### UNIT – IV

#### Flexural Stresses:

Theory of simple bending – Assumptions – Derivation of bending equation:  $M/I = f/Y = E/R$  – Neutral axis – Determination of bending stresses – Section modulus of rectangular and circular sections (Solid and Hollow), I, T, Angle and Channel Sections – Design of simple beam sections.

#### Unit Outcomes

- Derive bending equations
- Compute the flexural stresses for different cross sections.
- Design beam sections for flexure

### UNIT – V

#### Shear Stresses:

Derivation of Formula-Shear stress distribution across various beam sections like rectangular, circular, triangular, I, T and angle sections. Combined bending and shear.

**Analysis of trusses** by Method of Joints & Sections.

#### Unit Outcomes

- Determine shear stresses for different shapes.
- Evaluate effect of combined bending and shear on sections

#### Course Outcomes:

On completion of the course, the student will be able to:

- Understand the different types of couples and force systems
- Determine the centroid and moment of inertia for different cross-sections
- Understand the concepts of stress, strain, generalized Hooke's law, elastic moduli and strain energy.
- Develop shear force and bending moment diagrams for different load cases.
- Compute the flexural stresses and shear stresses for different loading cases and different cross-sections.

#### Text Books:

1. S. Timoshenko, D.H. Young and J.V. Rao, "Engineering Mechanics", Tata McGraw-Hill Company.
2. Sadhu Singh, "Strength of Materials", 11th edition 2015, Khanna Publishers.

#### References:

1. S.S. Bhavikatti, "Strength of materials", Vikas publishing house Pvt. Ltd.
2. R. Subramanian, "Strength of Materials", Oxford University Press.
3. R. K. Bansal, "Strength of Materials", Lakshmi Publications House Pvt. Ltd.
4. Advanced Mechanics of Materials – Seely F.B and Smith J.O. John Wiley & Sons inc., New York.

***I B.Tech II Semester Regular Examinations***  
**STRENGTH OF MATERIALS**  
**(CIVIL ENGINEERING)**

Max. Marks: 70

Time: 3 Hours

\*\*\*\*\*

Answer *all five* units by choosing one from each unit (5 x 14 = 70Marks)

**UNIT-I**

|            |  |           |
|------------|--|-----------|
| <b>Q.1</b> | State and explain the following law of forces:<br>1. Law of parallelogram of forces<br>2. Law of triangle of forces<br>3. Law of polygon of forces | <b>14</b> |
|------------|--|-----------|

**OR**

|            |   |           |
|------------|---|-----------|
| <b>Q.2</b> | Determine the center of gravity and M.O.I of the T-Symmetric section shown in fig. about its centroid axes X-X and Y-Y. | <b>14</b> |
|------------|---|-----------|

**UNIT - II**

|            |   |           |
|------------|---|-----------|
| <b>Q.3</b> | Draw the stress strain diagram for mild steel and explain the salient points. | <b>14</b> |
|------------|---|-----------|

**OR**

|            |  |          |
|------------|--|----------|
| <b>Q.4</b> | a) A steel rod of 4 m long and 20 mm diameter is subjected to an axial tensile load of 40 kN, determine the change in length, diameter and volume of the rod. Take $E = 2 \times 10^5 \text{ N/mm}^2$ and Poisson's ratio = 0.25 | <b>7</b> |
|            | b) Determine the expression for strain energy stored in a body, when the load is applied <b>suddenly</b> .   | <b>7</b> |

**UNIT-III**

|            |   |           |
|------------|---|-----------|
| <b>Q.5</b> | a) Explain the various types of loads acting on the beams.  | <b>4</b>  |
|            | b) Draw shear force and bending moment diagram for the beam shown below. Mark all salient values on them. Comment on point of contra flexure. | <b>10</b> |



|            |  |   |           |
|------------|--|---|-----------|
|            |  |   |           |
| <b>OR</b>  |  |   |           |
| <b>Q.6</b> |  | A Cantilever 2 m long carries a varying load of zero at its free end to maximum of 20kN/m at fixed end. Draw shear force and bending moment diagrams for the cantilever | <b>14</b> |

**UNIT-IV**

|            |  |   |           |
|------------|--|---|-----------|
| <b>Q.7</b> |  | What are the assumptions in theory of bending and derive the expression for bending equation?   | <b>14</b> |
| <b>OR</b>  |  |   |           |
| <b>Q.8</b> |  | A rectangular beam of 300 mm deep is simply supported over a span of 4 m. what U.D.L per meter, the beam can carry if the bending stress is not to exceed 120 N/mm <sup>2</sup> ? Take $I=8 \times 10^6 \text{ mm}^4$ | <b>14</b> |

**UNIT-V**

|             |  |   |           |
|-------------|--|---|-----------|
| <b>Q.9</b>  |  | Derive an expression for shear stress distribution for rectangular section?   | <b>14</b> |
| <b>OR</b>   |  |   |           |
| <b>Q.10</b> |  | A rectangular beam 100 mm wide and 150 mm deep is subjected to a shear-force of 30 kN, Determine i) Avg. shear stress, ii) Maxi. Shear stress, iii) shear stress at a distance of 25 mm above neutral axis. | <b>14</b> |

**K.S.R.M. COLLEGE OF ENGINEERING,(AUTONOMOUS),KADAPA**  
**B.Tech II Sem EEE (R20)**  
**Model Question Paper**  
**Sub: ELECTRICAL CIRCUIT ANALYSIS-I**

**Max Marks 60**

**Time:180 Min**

-----  
**Note: Answer all Questions . Each Question carries equal marks.**

**UNIT-I**

1. a) Explain Kirchoff's laws. 6M
- b). Determine the equivalent resistance between the terminals a-b for the network given below. 6M

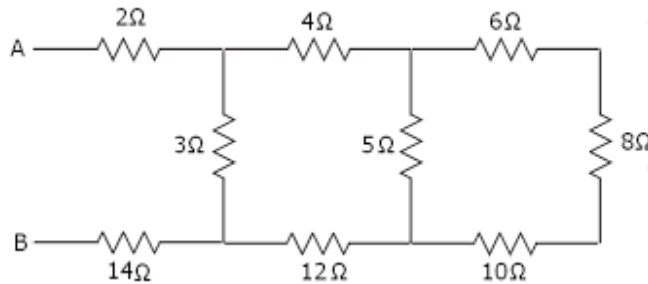

(OR)

2. Define self and mutual inductances and determine coefficient of coupling for the single phase transformer. 12M

**UNIT-II**

3. a) Define RMS and Average values and determine for a sinusoidal waveform. 8M
- b) A circuit having a resistance of  $20\Omega$  and inductance of  $0.07\text{H}$  is connected in parallel with a series combination of  $50\Omega$  resistance and  $60\mu\text{F}$  capacitance. Calculate the total current, when the parallel combination is connected across  $230\text{V}$ ,  $50\text{Hz}$  supply. 4M

OR

4. a). Show that average power through pure inductor is equal to zero. 8M
- b).An impedance coil in parallel with a  $100\mu\text{F}$  capacitor is connected across a  $200\text{V}$ ,  $50\text{Hz}$  supply. The coil takes a current of  $4\text{A}$  and the power loss in the coil is  $600\text{W}$ . Calculate (i) the resistance of the coil (ii) the inductance of the coil (iii) the power factor of the entire circuit. 4M

**UNIT-III**

5. State maximum power transfer theorem and obtain the condition to obtain maximum power. 12M

(OR)

6. a) State and explain Milliman's Theorem. 6M  
b). Determine current in 10 ohms resistor using superposition theorem for the network shown below. 6M

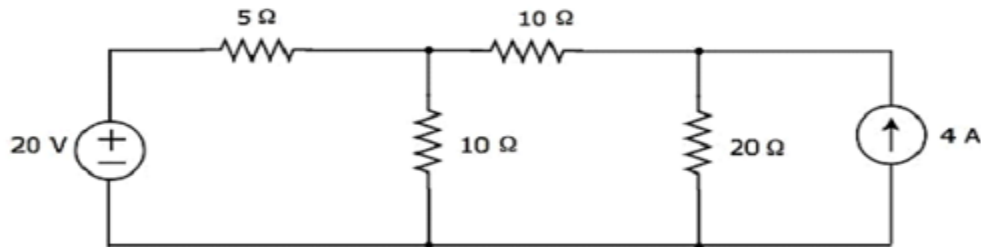

**UNIT-IV**

7. Derive the expression for line and phase currents and voltages of balanced star connected load with necessary phasor diagrams. 12M

(OR)

8. a) Three coils each having resistance of  $10\ \Omega$  and inductance of  $0.02\ \text{H}$  are connected in star across  $440\text{V}$ ,  $50\text{HZ}$ , three phase ac supply. Calculate the line currents and power consumed. 6M  
b) Derive the expression for measurement of active power for three phase balanced loads. 6M

**UNIT-V**

9. Obtain the fundamental tie-set matrix and write the necessary equilibrium equation for the graph given below. Select 2,3,6 as tree branches. 12M

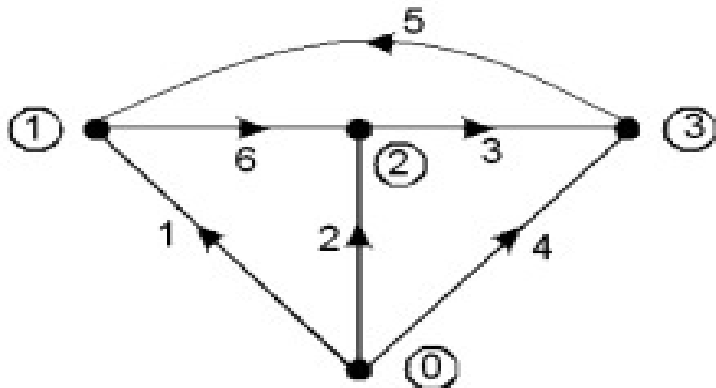

OR

- 10 a) Explain the procedure to form dual network with some dual pairs. 6M  
b) Obtain the dual network for the network shown below. 6M

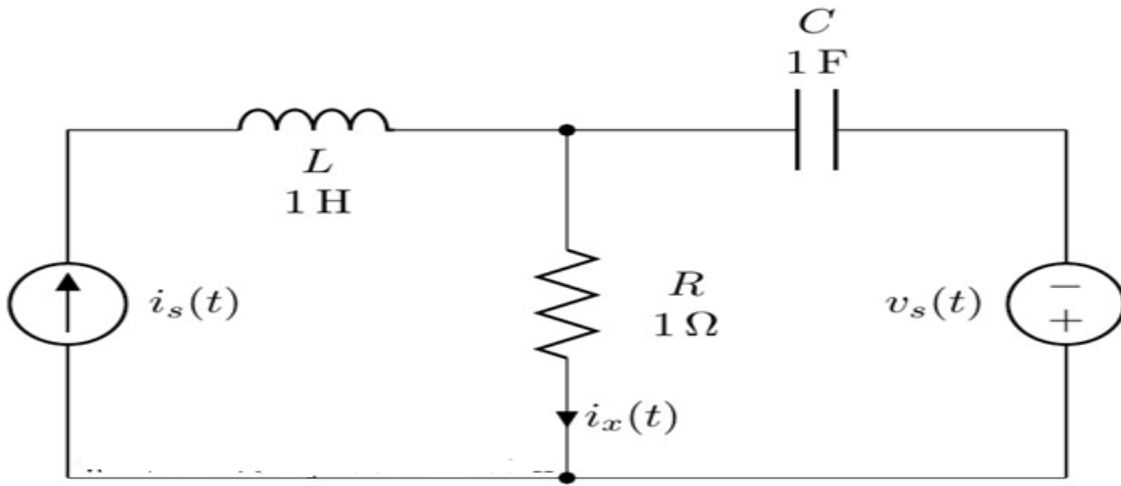

7

**K.S.R.M COLLEGE OF ENGINEERING (AUTONOMOUS), KADAPA**

B.Tech. II Sem. (R20) Regular Examinations of OCT 2021

**SUB: - MATERIAL SCIENCE**

MODEL PAPER

Time: - 3Hours

Max Marks: - 60

Answer any FIVE Questions choosing one question from each unit

All questions carry Equal Marks

**UNIT-I**

1. Draw the sketches of Simple cubic (SC), FCC & BCC Structures and the Explain the Atomic packing factor for the unit cells

(OR)

2. Explain Phase rule, Analyze the Iron-Iron carbide ( $Fe-Fe_3C$ ) Equilibrium diagram with Neat Sketch and Explain How it Segregate cast Irons & Steels

**UNIT-II**

3. Write the Classifications of Cast Iron, Draw and Explain the Characteristics, Microstructure, compositions and Applications of 'Gray Cast-Iron'

(OR)

4. Write the Classifications of Steels, Explain the Percentage of compositions and purpose Applications of 'HSS Steels (High speed Tool Steels)

**UNIT-III**

5. Draw and explain the various parameters occurs in TTT Diagram for Eutectoid steels

(OR)

6. Classify the 'Heat treatment operations' and Describe the Principle and operations of 'Flame Hardening' with Neat sketch

**UNIT-IV**

7. Explain The Microstructure, Properties and Applications of Non-Ferrous metals of 'Copper and its Alloys'

(OR)

8. Explain The Microstructure, Properties and Applications of Non-Ferrous metals of "Aluminum and its Alloys"

**UNIT-V**

9. Define and Classify the Composite Materials with its Properties and Applications

(OR)

10. Describe the Properties and Applications of Nano Materials



**K.S.R.M COLLEGE OF ENGINEERING (AUTONOMOUS), KADAPA**

B.Tech. II Sem. (R20) Regular Examinations of oct 2021

**SUB: - ENGINEERING DRAWING**

(COMMON TO ME, CSE)

MODEL PAPER

Time:- 3Hours

Max Marks:- 60

Answer any FIVE Questions choosing one question from each unit

All questions carry Equal Marks

**UNIT-I**

1. Construct a parabola, with the distance of the focus from the directrix as 50. Also, draw normal and tangent to the curve, at a point 40 from the directrix.

(OR)

2. Construct a cycloid, given the diameter of the generating circle as 40. Draw tangent to the curve at a point on it, 35 from the line.

**UNIT-II**

3. A line AB of 100mm length, is inclined at an angle of  $30^\circ$  to HP and  $45^\circ$  to VP The point A is 15mm above HP and 20mm in front of VP Draw the projections of the line.

(OR)

4. Draw the projections of a hexagonal pyramid, with side of base 30 mm and axis 70 mm long, high is resting with a triangular face on HP such that, the axis is parallel to VP. Follow the change of position method.

**UNIT-III**

5. A cube of side 40 mm, is resting on HP on one of its faces, with a vertical face inclined at  $30^\circ$  to VP. It is cut by a section plane inclined at  $45^\circ$  to HP and passing through the axis at 8 mm from the top surface. Draw the projections of the solid and also show the true shape of the section.

(OR)

6. A cylinder of diameter of base 40 mm and axis 55 mm long, is resting on its base on HP It is cut by a section plane, perpendicular to VP and inclined at  $45^\circ$  to HP. The section plane is passing through the top end of an extreme generator of the cylinder. Draw the development of the lateral surface of the cut cylinder.

## UNIT-IV

7. Draw an isometric view of orthographic projections shown below.

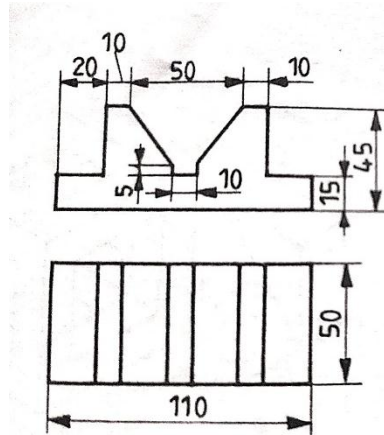

(OR)

8. Draw the front view, top view and side view of given object below. All dimensions are in mm.

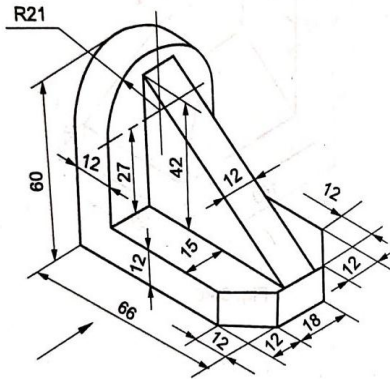

## UNIT-V

9. A hexagonal plane of side 30 is resting on an edge on the ground with its surface inclined at  $30^\circ$  to P.P. The nearest corner of the plane is 10 away from P.P. The station point is 50 in front of P.P. and 80 above G.L. and in the central plane of the object. Draw its perspective.

(OR)

10. A pentagonal pyramid of side of base 25 and height 50, rests with an edge of the base, touching the P.P. The station point is on the central line passing through the apex and 80 from P.P. and 65 above the ground. Draw the perspective view of the solid.



**KSRM COLLEGE OF ENGINEERING, KADAPA  
(AUTONOMOUS)  
B. TECH., II SEM (R20)  
DEPARTMENT OF ECE  
SUB: ELECTRONIC DEVICES & CIRCUITS  
MODEL QUESTION PAPER**

**Time: 3 Hrs**

**Max. Marks: 60**

---

**Note: Answer all questions choosing *one* from each unit  
All questions carry equal marks**

**UNIT - I**

1. (a) Write a short note on drift and diffusion currents. (6M)  
(b) Explain the operation of a PN junction diode under forward biased condition. (6M)

(OR)

2. (a) Derive an expression for depletion capacitance of a PN junction diode. (6M)  
(b) Write about the constant voltage drop modeling of diode forward characteristics. (6M)

**UNIT - II**

3. (a) Explain the operation of a Zener diode under reverse biased condition. (6M)  
(b) Explain the operation of a half wave rectifier. (6M)

(OR)

4. (a) Draw the circuit of a voltage doubler and explain the operation. (6M)  
(b) Explain the operation of an NPN transistor. (6M)

**UNIT - III**

5. (a) Draw the voltage transfer characteristics of a BJT and explain. (6M)  
(b) Draw the Hybrid pi model of a BJT and explain. (6M)

(OR)

6. Draw the circuit of a CE amplifier and draw its equivalent small signal model. Also derive the expressions for input impedance, output impedance and voltage gain. (12M)

### **UNIT - IV**

7. (a) Draw the structure of an n channel enhancement MOSFET and explain the operation. (6M)  
(b) Write a short note on CMOS transistor. (6M)

(OR)

8. (a) Draw the structure of a p channel enhancement MOSFET and explain the operation. (6M)  
(b) Draw the  $i_D$  vs  $V_{DS}$  characteristics curve of a MOSFET and explain. (6M)

### **UNIT - V**

9. (a) Draw the small signal equivalent model of a MOSFET and explain. (6M)  
(b) Define transconductance and derive its expression. (6M)

(OR)

10. Draw the circuit of a CS amplifier and draw its equivalent small signal model. Also derive expressions for input impedance, output impedance and voltage gain. (12M)

**Subject code: 2005203**

**K.S.R.M. COLLEGE OF ENGINEERING (AUTONOMOUS),KADAPA**

**B.Tech I Year II Semester (R20) Regular Examinations, October 2021**

**C PROGRAMMING & DATA STRUCTURES**

**(Common to CE, ECE)**

**Time: 3 hours**

**Max.Marks: 60**

---

**Answer any FIVE Questions Choosing One Question from each unit.**

**All Questions carry equal marks.**

**UNIT –I**

1.a. Define Expression and explain in detail about Expressions with example? 6M

b. Explain Switch statement with an example? 6M

**or**

2.a. Write a C program to find sum of individual digits of a given number? 6M

b. Explain Jumping statements and their use in c language? 6M

**UNIT –II**

3.a . What is a function? When we use functions mention the uses of functions?6M

b. Explain in detail about Two dimensional arrays with an example? 6M

**or**

4. a. Explain about storage classes in c? 6M

b. Define string? Explain about String handling functions in c? 6M

**UNIT-III**

5. a. What is a Pointer? Explain how pointers can be declared and initialized? 6M

b. Explain chain of pointers with suitable example? 6M

**or**

6.a. Differentiate Structures and unions with suitable example? 6M

b. Explain Array of Structures in detail? 6M

**UNIT-IV**

7.a. What is a Stack? Implement Stack operations Using C program? 6M

b. What is Searching? Explain in detail about Linear search? 6M

**or**

8. What is Sorting? Explain in detail about Bubble Sort with an Example? 12M

**UNIT-V**

9.a. What is a Linked List? Explain Single Linked list? 6M

b. Explain single linked list operations? 6M

**or**

10. Why we use Trees in Data structures. Explain in detail about Binary trees?12M

**K.S.R.M.COLLEGE OF ENGINEERING (AUTONOMOUS), KADAPA**

I B. TECH II SEM (R20) Model Question Paper

**Sub: (2005204) Python Programming**

Time: 3Hours

(CSE)

Max.Marks:60

---

**Note:** Answer any **FIVE** questions by choosing **ONE** question from each unit.

All questions carry **Equal** marks.

**Unit - I**

1. a) What are the Naming Conventions in Python? Give examples. [6M]
- b) Explain Input and Output statements in python with suitable programming examples. [6M]

(OR)

2. a) Explain in detail about the various operators in Python with suitable examples. [6M]
- b) What are the different data types available in Python, Explain in detail [6M]

**UNIT-II**

3. a) What is assert statement? Explain assert statement with a suitable python program [5M]
- b) List and explain control statements in python. Give a suitable python program for each control statement. [7M]

(OR)

4. a) Write a Python program to find the given year is leap year or not [5M]
- b) What is an array? Explain array methods with suitable examples. [7M]

**UNIT-III**

5. a) Explain local and global variables with a suitable python program [5M]
- b) Explain the following with a suitable python program. [7M]
  - a) filter () b) map() c) reduce()

(OR)

6. a) Can a function return multiple values? If yes, Explain with a suitable python program [6M]
- b) What is recursion? Write a python program to find factorial of a given number using recursion. [6M]

#### **UNIT-IV**

7. a) Explain list methods with suitable examples [6M]  
b) Write a python program to find number of occurrences of each letter in a string using dictionary [6M]

(OR)

8. a) Write a Python program on the following concepts.  
i) Write data into a file ii) read data from a file [6M]  
b) Write a python program to insert an element into a tuple. [6M]

#### **UNIT-V**

9. a) What are different types of inheritance supported by Python? Explain with suitable examples. [6M]  
b) What is an operator overloading? Explain operator overloading with a suitable example. [6M]

(OR)

- 10.a) What is an abstract class? Implement abstract class with a suitable python program. [6M]  
b) Can python support method overloading? If not how to achieve method overloading in python? Briefly discuss. [6M]

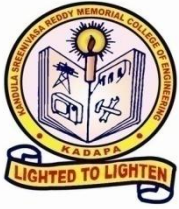

# K.S.R.M. COLLEGE OF ENGINEERING

(AUTONOMOUS)

Kadapa, Andhra Pradesh, India– 516 003

I B.Tech., II Semester (R20 UG)

Differential Equations and vector Calculus (Subject Code 2021201)

(Common to All Branches)

Time: 3 Hours

MODEL PAPER

Max. Marks: 60

Note: Answer any **FIVE** questions by choosing ONE from each unit.

All questions carry equal marks.

## UNIT - I

1 Solve  $(D - 2)^2 y = 8(e^{2x} + \sin 2x + x^2)$ . (12M)

(OR)

2 Solve, by the method of variation of parameters,  $(D^2 + a^2)y = \tan ax$ . (12M)

## UNIT - II

3 (a) Find the partial differential equation of all spheres whose centers lie on the z-axis. (6M)

(b) Form the partial differential equation by eliminating the function  $f$  from the relation (6M)

$$f\left(\frac{y}{x}, x^2 + y^2 + z^2\right) = 0$$

(OR)

4 (a) Solve  $\frac{y^2 z}{x} p + xzq = y^2$  (6M)

(b) Solve  $x^2(y - z)p + y^2(z - x)q = z^2(x - y)$  (6M)

## UNIT - III

5. Using the method of separation of variables, solve

$$4 \frac{\partial u}{\partial x} + \frac{\partial u}{\partial y} = 3u \text{ given } u = 3e^{-y} - e^{-5y} \text{ when } x = 0. \quad (12M)$$

(OR)

6. A tightly stretched string of length  $l$  has its ends fastened at  $x = 0$  and  $x = l$ . The mid-point of the string is then taken to height  $h$  and then released from rest in that position, find the displacement  $y(x, t)$ . (12M)

**UNIT – IV**

7. (a) Find a unit normal vector to the surface  $xy^3z^2 = 4$  at the point  $(-1, -1, 2)$ . (6M)  
(b) Show that  $\nabla^2(r^n) = n(n+1)r^{n-2}$  where  $\vec{r} = x\vec{i} + y\vec{j} + z\vec{k}$ . (6M)  
(OR)
8. A vector field is given by  $\vec{F} = (x^2 - y^2 + x)\vec{i} - (2xy + y)\vec{j}$ . Show that the vector field is irrotational and find its scalar potential function. (12M)

**UNIT – V**

9. Verify Stokes's theorem for  $\vec{F} = (x^2 + y^2)\vec{i} - 2xy\vec{j}$  taken around the rectangle bounded by the lines  $x = \pm a, y = 0, y = b$ . (12M)

(OR)

10. (a) Find the work done in moving a particle in the force field  $\vec{f} = 3x^2\vec{i} + (2xz - y)\vec{j} + z\vec{k}$  along the straight line from  $(0, 0, 0)$  to  $(2, 1, 3)$ . (6M)
- (b) Apply Green's theorem to evaluate  $\int_C [(2x^2 - y^2)dx + (x^2 + y^2)dy]$ , where C is the boundary of the area enclosed by the x-axis and the upper- half of the circle  $x^2 + y^2 = a^2$ . (6M)



**Subject Code: 2023202 / R20**

**K.S.R.M COLLEGE OF ENGINEERING, KADAPA  
(AUTONOMOUS)  
MODEL QUESTION PAPER  
FOUR YEAR B. TECH DEGREE EXAMINATIONS  
I B. TECH II SEMESTER REGULAR EXAMINATION  
SUB: CHEMISTRY  
(ECE, EEE)**

**Time : 3hrs**

**Max marks :60M**

**Answer any Five questions choosing one question from each unit. (12x5=60M)**

**UNIT-I**

1. (a) Define Electromagnetic radiation and write notes on properties of waves (6M)  
(b) Discuss in brief about Schrodinger wave equation and significance of  $\Psi$  &  $\Psi^2$  (6M)  
(Or)
2. (a) Outline the postulates of LCAO theory and draw molecular orbital diagram for any CO molecule. (8M)  
(b) Write short notes on Planck's quantum theory (4M)

**UNIT-II**

3. (a) Outline the postulates of Crystal field theory and write notes on crystal field splitting in Octahedral Complexes. (8M)  
(b) Write short notes on applications of Nanomaterials (4M)  
(Or)
4. (a) Define doping and write notes on types of doping. (6M)  
(b) Illustrate Band theory of Solids (6M)

**UNIT-III**

5. (a). Summarize Conductometric titrations of strong acid vs strong base and weak acid vs Strong base (8M)  
(b). Define battery and explain any one example for Secondary battery (4M)  
(Or)
6. (a) Define Electrochemical cell and write notes on Galvanic Cell (6M)  
(b) Derive Nernst equation (6M)

#### UNIT-IV

7. a) Define Addition polymerization and explain the mechanism involved in addition polymerization with examples. (10M)

b) Write any four differences between Thermoplastics and Thermosets (2M)

(Or)

8. (a) Outline the synthesis, properties and applications of Bakelite (6M)

(b) Write short notes on conducting polymers (6M)

#### UNIT-V

9. (a) Summarize the molecular Vibrations in IR Spectroscopy (8M)

(b) Write notes on Beer- Lambert's law (4M)

(Or)

10. (a) Illustrate Thin layer Chromatography (6M)

(b) Explain atomic and Molecular absorptions (6M)

Question Paper Code: 2024103

College Code: 9Y

**K.S.R.M. COLLEGE OF ENGINEERING: : KADAPA.**

**(Autonomous)**

**I B. Tech II Sem (R20) Model Question paper - September/October 2021**

**COMMUNICATIVE ENGLISH**

**(Common to M.E & C.S.E)**

**Time: 3 Hrs.**

**Max. Marks: 60**

**Note: Answer all FIVE Units. All questions carry equal marks. (5x12=60)**

**UNIT: 1**

1. A) What is William Hazlitt son's attitude towards his new school as described in "On the Conduct of Life"? 7M
- B) Give the meaning of the idioms and phrases and use them in sentences of your own. 1X5=5M
- i) at the eleventh hour ii) bread and butter iii) man of letters  
iv) take off v) break up.

**OR**

2. A) What is word formation? Discuss various types of word formation? 7M
- B) i) She succeeded in her attempt. (Rewrite the sentence by using adjective of 'succeeded') 1X3=3M
- ii) Respect your parents and teachers. (Rewrite the sentence by using 'respect' as a Noun)
- iii) She works with diligence. (Rewrite the sentence by using Adverb of 'diligence')
- C) i) Give antonyms of the following. ½ X 2 =1M
- a) modest b) prosperity
- ii) Give synonyms of the following ½ X 2=1M
- a) affection b) famous

**UNIT: 2**

3. A) Appreciate the poem **The Brook** written by Alfred Lord Tennyson. 7M
- B) Fill in the blanks with the right verb forms from the verbs given in brackets 1x5= 5M
- a) I \_\_\_\_\_ (attend) the function Yesterday.
- b) Oil \_\_\_\_\_ (float) on water.
- c) Look! The old man \_\_\_\_\_ (cross) the road.
- d) She was taking dinner when cell phone \_\_\_\_\_ (ring).
- e) English \_\_\_\_\_ (be) spoken in many parts of the world.

**OR**

4. A) Make **FOUR** meaningful sentences on the following pattern. 1x4= 4M

| Subject + | Verb +  | Object + | To infinitive |
|-----------|---------|----------|---------------|
| They      | advised | me       | to study well |

**B) Fill in the blanks with ‘A, An or The’**

**1X3= 3M**

- a) He met with .....accident yesterday.
- b) Please give me.....copy of The Times of India.
- c) .....earth revolves round the sun.

**C) Fill in the blanks with suitable prepositions**

**1X5= 5M**

- a) Praneeth is playing tennis\_\_\_\_\_ Sunday.
- b) We are going to see my parents\_\_\_\_\_ the weekend.
- c) My friend has been living in Chennai \_\_\_\_\_ 2020
- d) I will have finished this essay \_\_\_\_\_Friday.
- e) Mumbai is famous \_\_\_\_\_its textile mills.

**UNIT: 3**

**5. A) How does Oliver Goldsmith bring out the sufferings of the poor in his essay, ‘A City Night Piece?’**

**7M**

**B) Convert the following sentences as directed.**

**1X5 = 5M**

- a) She told me that the test was difficult.(change into Direct Speech)
- b) She says, “I am a little bit nervous.”(change into Indirect Speech)
- c) The teacher said to me, “Shut the door.”(change into Indirect Speech)
- d) Karthik asked me why I was late that day. (change into Direct Speech)
- e) She said, “Alas! My brother failed in the test.”(change into Indirect Speech)

**OR**

**6. A) Convert the following sentences as directed.**

**1x6 = 6M**

- a) Kritika is not chopping vegetables.(change into Passive Voice)
- b)The newspaper has been read by me. (change into Active Voice)
- c)They will post the letter. (change into Passive Voice)
- d) Did she do her duty? (change into Passive Voice)
- e) Let the song be sung by her. (change into Active Voice)
- f) The thief was caught. (change into Active Voice)

**B) Convert the following sentences as directed.**

**1x6 = 6M**

- a).Suraj is the most intelligent of all boys.(change into Positive Degree)
- b) Rose is as beautiful as tulip. (change into Comparative Degree)
- c) No other army in the world is as mighty as Indian army.(change into Superlative Degree)
- d) Very few cities in India are as beautiful as Lucknow.(change into Superlative Degree)

- e) Govind is not the laziest boy in the class.(change into Positive Degree)  
 f) I have never met so good a man as he. (change into Comparative Degree)

**UNIT: 4**

7. A) What did you understand in Chetan Bhagath’s essay ‘Being rich, Being good’? **7M**

B) Covert the following Pie chart texting it verbally. **5M**

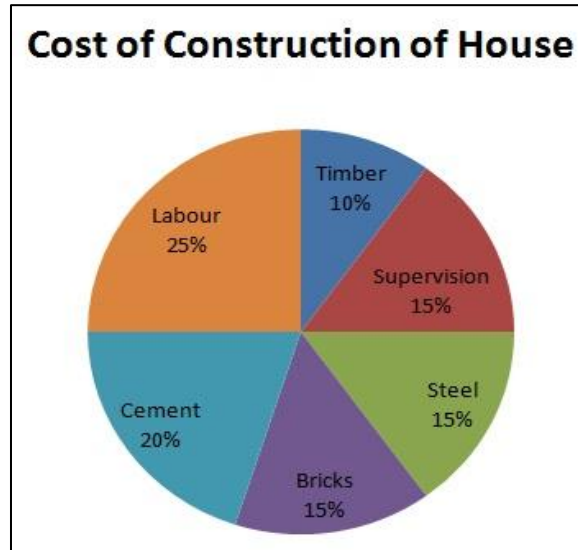

**OR**

8. A) Convert the following sentences as directed. **1x6 = 6M**

- a) As she won the beauty contest, she cried with joy. (convert into Simple Sentence)  
 b) He is too weak to carry the box. (convert into Complex Sentence)  
 c) Although they lost the match, they were not disgraced. (convert into Compound sentence)  
 d) You must take rich diet, or you will not gain weight. (convert into Simple Sentence)  
 e) Because of his illness, he could not join the meeting. (convert into Compound Sentence)  
 f) I saw a wounded tiger. (Convert into Complex Sentence)

B) Add question tags to the following statements. **1x6 = 6M**

- a) He answered my question. \_\_\_\_\_?  
 b) Let us go to movie. \_\_\_\_\_?  
 c) I am a student. \_\_\_\_\_?  
 d) She will help you. \_\_\_\_\_?  
 e) We cannot do this together. \_\_\_\_\_?  
 f) We seldom see the dogs. \_\_\_\_\_?

**UNIT: 5**

**9. A) Why is George Orwell's essay "Politics and the English Language" significant? 7M**

**B) Read the passage given below and answer the questions that follow:**

The culture of nuclear families is in fashion. Parents are often heard complaining about the difficulties in bringing up children these days. Too much of freedom in demand, too much independence; overnight parties; excessive extravagance, splurging pocket money; no time for studies and family - all this is a common cry of such families. Aren't parents, themselves, responsible for this pitiful state? The basic need of a growing youth is the family, love, attention and bonding along with moral values. One should not forget that 'charity begins at home'. Independence and individuality both need to be respected, in order to maintain the sanctity of family.

**Questions:**

1. Mention any two major common concerns of a nuclear family. **1 x 5 = 5 M**
2. Who, according to the passage, are responsible for common concerns?
3. Explain the expression 'charity begins at home'.
4. What are needed to be respected in order to maintain the sanctity of family?
5. Pick out the word from the passage which means 'pious'?

**OR**

**10. A) Correct the following sentences if necessary. 1 x 7 = 7 M**

- a) I told these news to my father.
- b) One should keep his promises.
- c) You have much dresses.
- d) He speaks loudly than his brother.
- e) Amartya Sen is one of the few Indians who has won the Nobel Prize.
- f) I thanked him for what he did.
- g) He worked hard and he failed.

**B) Write the conversation between two friends on making plans for the weekend? 5M**

---